

## **Flexural Behaviors of Precast Reinforced Concrete-EPS foam-Steel Deck Hybrid Panel**

Mardiana Oesman<sup>1\*</sup>

<sup>1</sup>*Civil Engineering Department, Bandung State Polytechnic, Jl. Gegerkalong Hilir, Ciwaruga, Kec. Parongpong, Kabupaten Bandung Barat, Jawa Barat 40559, Indonesia.*

\* *Corresponding author: mardianaesman@polban.ac.id*

(Received: September 23<sup>rd</sup> 2021 ; Accepted: October 21<sup>st</sup> 2021)

**Abstract:** This paper presented the flexural behavior of the newly developed hybrid panel which included the comparison of the ultimate load, load-deflection behavior, and failure modes. The experimental study was carried out on precast reinforced concrete-EPSfoam-steel deck hybrid panels (CES) consist of three layers of material : concrete layer is on the top, the steel deck is located on the bottom layer, and the EPS foam layer as the core. The dimensions of CES are 300 mm x 1200 mm with thickness of concrete layer and EPS foam as variables. The concrete thick were 30 mm and 40mm. The density of EPS foam was 12 kg/m<sup>3</sup>, 20 kg/m<sup>3</sup>, and 30 kg/m<sup>3</sup>. The static flexural test of CES was conducted in accordance with the ASTM C 393-00 standard for determination of flexural strength on concrete, the load was applied at third-point loading. This test was carried out with monotonic static load, deflection control using a loading frame with capacity of 10 kN. The results show that increase the thickness of the concrete layer from 30mm to 40mm with EPSfoam density of 12 kg /m<sup>3</sup>, 20 kg/m<sup>3</sup>, and 30 kg/m<sup>3</sup> achieved a maximum load increase of 33.51%; 46,13%; and 37.35%, respectively. The use of EPSfoam layer with proper density affects behavior and the collapse mechanism, the low density caused a poor collapse mechanism; conversely, the high density caused premature failure. Core shear and delamination were identified as the failure mode of the CES. The CES with 40mm concrete thick, density of 12 kg /m<sup>3</sup> show the best behavior.

**Keywords:** *Delamination; EPS foam density; flexural behavior; hybrid panel*

### **1. Introduction**

The hybrid concrete structure is generally a sandwich structure consisting of two face layers separated by a core material. The faces usually consist of thin and high performing material, such as composite laminates made from high strength concrete, while the core material is a low density with relatively low performing material, such as EPS foam which results in highly specific flexural behavior of hybrid sandwich panel. In general, the good behavior of reinforced concrete sandwich structures has a total thickness of the face layers twice the thickness of the core layer. The choice of constituent materials depends mainly on the specific application and design criteria of the sandwich panel products [1]. The most outstanding benefit of this type of composite structure is its high strength and stiffness to weight ratio [2-8]. On the other hand, this hybrid structure has several disadvantages, because the structure is a hybrid with different materials, it needs to be pursued so that the structure can work fully bonded, for example by adhesive or connectors between the outer layer and the core [3]. Several studies have been carried out to improve the behavior of the hybrid panel structure. The main concept proposed in this work, to improve high strength, stiffness to weight ratio, and to reduce the mass of panel. This include increasing the material properties of the outer layer or even differentiating the material used in

the outer layer so that it can anticipate stresses caused by bending loads; namely by using a steel deck on the bottom layer so that it is strong against tensile stress, and a reinforced concrete layer on the top layer so that it is resistant to compressive stress, and an EPS foam layer as the core layer. The aim of this paper was to investigate the structural behaviour of the newly developed hybrid panel under flexural loading which included the comparison of the ultimate load, load-deflection behaviour, and failure modes. The experimental study was carried out on precast reinforced concrete-EPS foam-steel deck hybrid panels (CES) consist of three layers of material: concrete layer is on the top, the steel deck is located on the bottom layer, and the EPS foam layer as the core.

## 2. Sample Preparations

Precast reinforced concrete -EPSfoam-steel deck hybrid panels (CES) specimen consists of three layers of material: concrete layer is on the top, the steel deck is located on the bottom layer, and the EPS foam layer as the core, as shown in Fig. 1. In order for the three layers of precast panels to work in a monolithic manner when loaded and erected, connectors between the layers, and shrinkage reinforcement in the concrete layer are needed. Moreover, adhesive is used to connect the steeldeck to the interface of the EPS foam (with the Aquaproof trademark), while the connector between the concrete layer and EPS foam are used vertical shear steel connectors as shown in Fig. 2. The dimensions of the precast concrete-EPSfoam-steel deck hybrid panel (CES) are 300 mm x 1200 mm with thickness of concrete layer as variables.

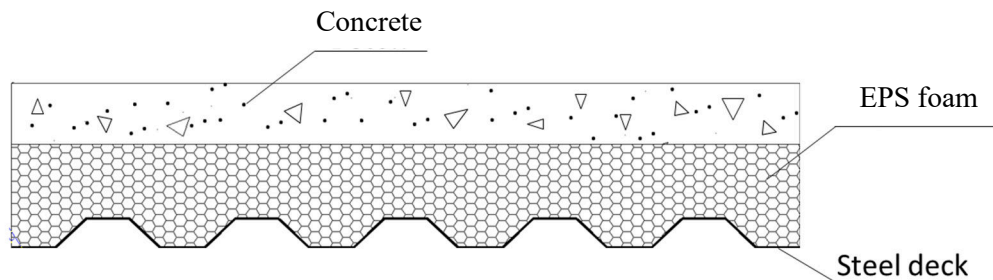

**Fig. 1.** Precast reinforced concrete -EPS foam-steel deck hybrid panels (CES) cross section

The characteristics of EPS core used in this research are presented in Table 1. Steel deck used was corrugated steel plate with zinc-aluminum coating, 4.5 mm thickness, produced by PT. Bluescope Lysaght, Indonesia. The specifications of this steel plate can be seen in Table 2. The concrete used was normal concrete with a design compressive strength of  $f_c = 17$  MPa. Composition of concrete mix can be seen in Table 3, and the concrete mix design refers to ACI 211.1-91. In this research, plain reinforcement with a diameter of 2.5 mm was used in concrete as shrinkage reinforcement. In addition, reinforcement was also used as a shear connector that connects the concrete layer and the EPS foam layer. The yield strength of reinforcement used is  $f_y = 500$  MPa.

**Table 1** Properties of EPS, core material

Density [kg/m <sup>3</sup> ]	Compression Strength [MPa]	Modulus of Elasticity [MPa]
12	0.0983	6.53
20	0.2123	7.00
30	0.3110	7.60

**Table 2.** Properties of steel deck

Properties	Value
Thickness	0.45 mm
Area	509.68 mm <sup>2</sup>
Moment of Inertia	233960 mm <sup>4</sup> /m
Section Modulus	9590.83 mm <sup>3</sup> /m
Massa	4.42 kg/m
Yield stress	550 MPa

**Table 3.** Concrete mix

Materials	Mix design
Portland cement	354.10 kg/m <sup>3</sup>
Course aggregate	776.51 kg/m <sup>3</sup>
Fine aggregate	1036.34 kg/m <sup>3</sup>
Water	249.19 kg/m <sup>3</sup>

The CES hybrid panel specimens were manually prepared. EPS foam used in this research consists of 2 kinds of thickness: 40mm and 50mm. The day before the concrete made, it began with gluing EPS foam on the steel deck. This was done, because the adhesive used was an adhesive material that was not easy to dry. So, this gluing process needed to be done the day before mixing. Immediately before making concrete, the steel deck and EPS foam that have been attached are put into the mold. After that, the shrinkage reinforcement was placed on the EPS foam. In addition to the installation of shrinkage reinforcement, vertical shear connectors were also installed every 150mm as shown in Fig.2.

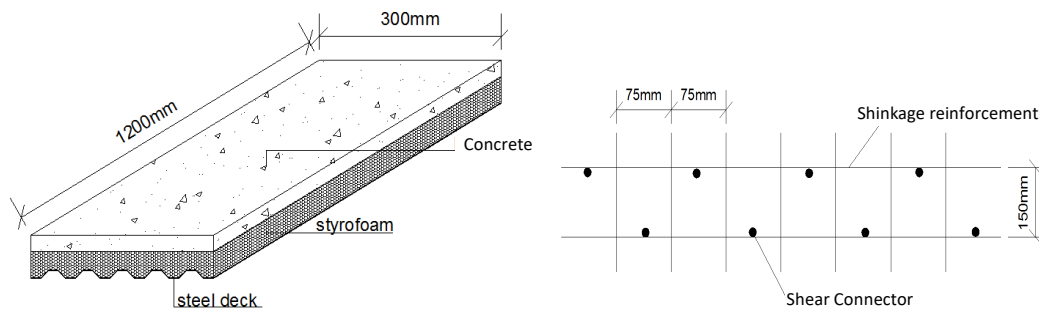
**Fig. 2.** The CES hybrid panel specimens

### 3. Experimental Procedure

The static flexural test of CES hybrid panels was conducted in accordance with the ASTM C 393-00 standard [9] which is a standard test method for determination of flexural strength on concrete, the load was applied at third-point loading. This flexural tests were carried out with monotonic static load, deflection control using a loading frame with capacity of 10 kN. The tests were carried out on 6 specimens of CES with variables: the density of EPS foam, and the thickness of the concrete layer. The thickness of the EPS form was 40 mm. The specification of the specimens as shown in Table 4. The set up of the flexural test are given in Fig. 3.

**Table 4.** CES specimen specification

Specimen	Concrete Thickness	EPS Density
CES-30-12	30 mm	12 kg/m <sup>3</sup>
CES-30-20	30 mm	20 kg/m <sup>3</sup>
CES-30-30	30 mm	30 kg/m <sup>3</sup>
CES-40-12	40 mm	12 kg/m <sup>3</sup>
CES-40-20	40 mm	20 kg/m <sup>3</sup>
CES-40-30	40 mm	30 kg/m <sup>3</sup>



**Fig. 3** The set up of the flexural test of CES hybrid panels

During the test, the applied load as well as the deflection that occurred in the middle of the span and at one-fourth of the span were recorded. For recording the vertical deflection using a dial gauge placed under the test object as shown in Fig. 4. In addition, during the testing, the failure mechanism of the CES hybrid panel was observed. It was observed crack patterns that occurred in the EPS foam and concrete elements, and changes in shape that might occur in the steel deck layer. Likewise, the change in thickness of the EPS foam structural element layer which was the core of the CES hybrid panel. The test was terminated after a visible collapse mechanism was encountered or the specimen was undergoing a large displacement but could not carry any increased load.



**Fig. 4.** Dial gauges placed under specimen for recording deflection

## **4. Result and Discussion**

### **4.1. Comparison of Ultimate Load**

Fig.5 shows the maximum load carrying capacity and deflection against the density type of EPS foam layer panels, with 30mm thick of concrete layer. The ultimate load for CES-30-12, CES-30-20, and CES-30-30 were 5.5kN, 6.00kN, and 6.50kN, respectively. The results indicated that

the load carrying capacity of the CES hybrid panel influenced by density of the EPS foam; the higher the density of the EPS foam, the higher the load carrying capacity of the CES hybrid panels.

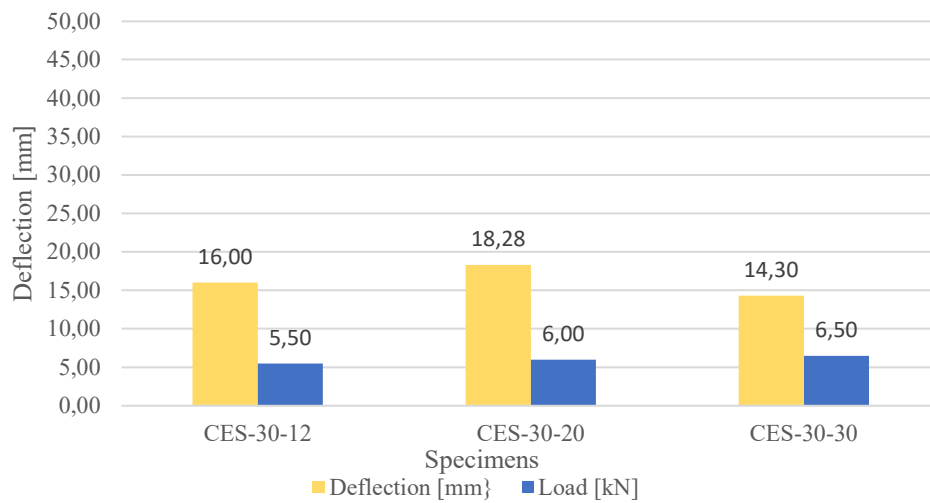

**Fig. 5.** Load-Deflection of CES hybrid panels with 30mm concrete thick

Therefore, Fig. 5 shows that load carrying capacity of the CES-30-30 hybrid panels was the highest. The difference in load carrying capacity between the CES-30-30 hybrid panels and CES-30-20 hybrid panels was 8.33%; while The difference in load carrying capacity between the CES-30-30 hybrid panels and CES-30-12 hybrid panels was 18.18%.

It can also be observed from this figure that the CES hybrid panels, with 30mm thick of concrete layer, CES-30-30 hybrid panel had highest stiffness. On the other hand, CES-30-12 hybrid panel had higher stiffness than CES-30-20 hybrid panel. The CES-30-20 hybrid panel and CES-30-12 hybrid panel reached the maximum load with a large deflection, while CES-30-30 hybrid panel reached the corresponding values with a fairly small deflection. The failure of the CES hybrid panels can be caused by various mechanisms within the constituent materials [1,5]. If a low density foam core is used in a the CES hybrid panels, it is very likely that they will fail either due to indentation or core shear [5]. Such mechanisms were clearly observed within the CES-30-20 hybrid panel and CES-30-12 hybrid panel, especially the indentation failure.

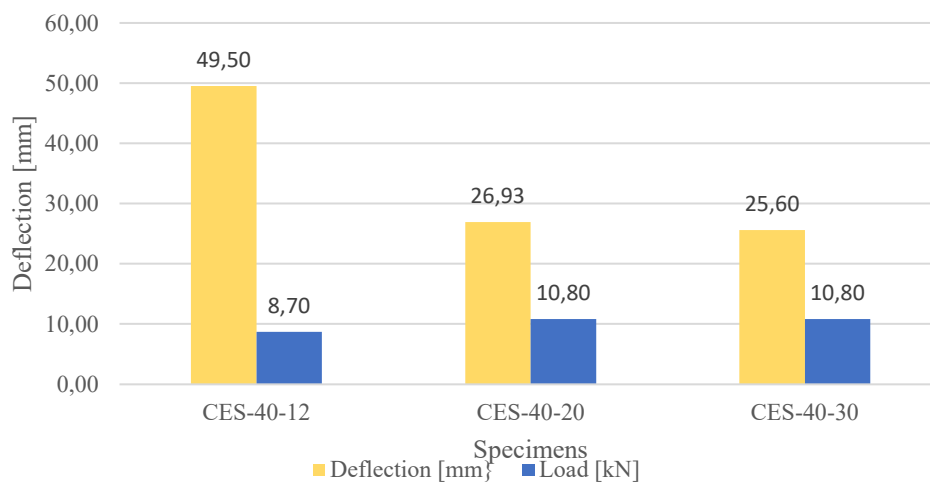

**Figure 6.** Load-Deflection of CES hybrid panels with 40mm concrete thick

Fig.6 shows the maximum load carrying capacity and deflection against the density type of EPS foam layer panels, with 40mm thick of concrete layer. The ultimate load for CES-40-12, CES-40-20, and CES-40-30 were 8.7 kN, 10.8 kN, and 10.8 kN, respectively. The maximum load carrying capacity EPS foam layer panels, with 40 mm thick of concrete layer quiet difference from that of the EPS foam layer panels with 30 mm thick of concrete layer. The results indicated that the difference in load carrying capacity between the CES-40-30 hybrid panels and CES-40-20 hybrid panels were the same, 10.80 kN. While, the difference in load carrying capacity between CES-40-30 and CES-40-20 hybrid panels to CES-40-12 hybrid panels was 24.14%.

It can also be observed from this figure that the EPS foam layer panels with 40mm thick of concrete layer, the CES-40-30 hybrid panel and CES-40-20 hybrid panel had higher stiffness than CES-40-12 hybrid panel. The results indicated that the difference in stiffness between the CES-40-30 to CES-40-20 hybrid panels and CES-40-12 hybrid panels, was 5.2 % and 140 %, respectively.

#### **4.2. Comparison of Load-Deflection Behaviour**

Fig. 7 shows the load-deflection of concrete EPS foam steel layer panels, with 30mm thick of concrete layer. The load-deflection graph of CES-30-30 hybrid panel showed that the specimen had the highest stiffness and reached the highest load capacity. While, the stiffness of CES-30-20 and CES-30-12 hybrid panels almost the same. On the other hand, Figure 8 shows the load-deflection of concrete EPS foam steel layer panels, with 40mm thick of concrete layer. The load-deflection graph of CES-40-30 hybrid panel and CES-40-20 showed that the specimens had the higher stiffness and reached the higher load capacity than that of CES-40-12 hybrid panels. The curves also show that the curves did not show descending curve to reaching failure, but due to a failure initiation in the specimens. It seemed that the failure occurred in a form of sudden cracking of the core layer, EPS form due to shear propagation. The graphs consisted of an initial linear part followed by a non-linear portion. After reaching the ultimate value, the testing was automatically terminated by the testing machine. It was assumed that there was a sudden crack at the core at the initial stage of failure mechanism, followed by delamination between the core and steel deck. In the hybrid panels with foam core, the slope of load-deflection curve will change as the panel began to rupture due to stretching and beyond that point, the foam almost uncontrollably deformed and finally collapsed at the maximum load [5].

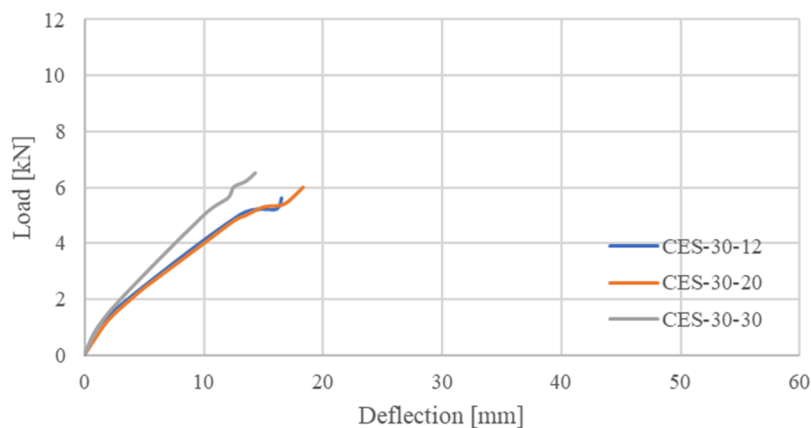

**Fig. 7.** Load-deflection curve of CES-30 panels

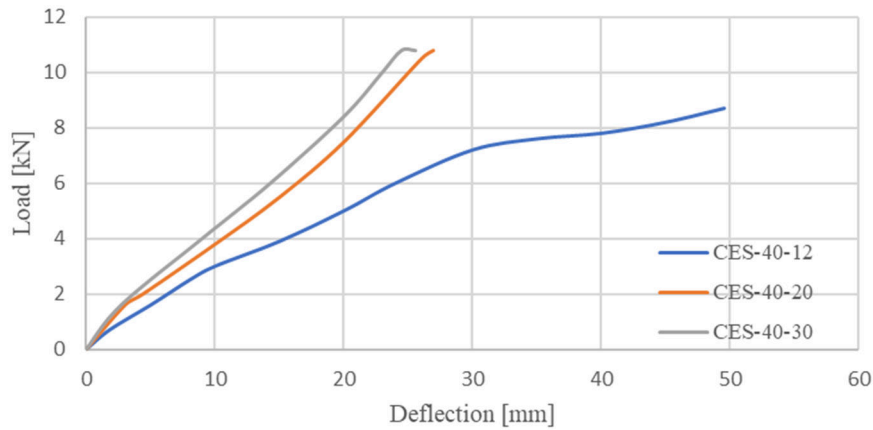

Fig. 8. Load-deflection curve of CES-40 panels

### 4.3. Comparison of failure mode

Figure 9 shows crack pattern on CES hybrid panel with 30mm concrete thick, and Figure 10 shows crack pattern on CES hybrid panel with 40mm concrete thick. At the beginning of loading, there was no noticeable crack pattern on all layers of the CES-30-12, CES-30-20, and CES-30-30 hybrid panels. In the CES30-12 hybrid panel, the higher the load given, the more deflection that occurred, as the compaction occurred in the middle of the span at the EPSfoam layer.



a. CES-30-12 panel



b. CES-30-20 panel



c. CES30-30 panel

Fig.9. Crack pattern of concrete EPS foam steel deck panel, 30mm concrete thick

## *Flexural Behaviors of Precast Reinforced Concrete-EPS foam-Steel Deck Hybrid Panel*

The compression of the EPS foam layer was decreasing towards the end of the span. This was not the case with CES-30-20 and CES-30-30 hybrid panels. This shows the EPS foam layer with a density of 20 kg/m<sup>3</sup> and 30 kg/m<sup>3</sup> behaved very rigidly which caused no compression (visually), and shaked that caused cracking openings so that the initial collapse of the hybrid panel occurred.

In all hybrid panels, the collapse began with a loud sound in the steel layer indicating the laminate process between the steel layer and the EPS foam layer followed by a change in the shape of the steel layer around the load point.



a. CES-40-12 panel



b. CES-40-20 panel



c. CES-40-30 panel

**Fig. 10.** Crack pattern of concrete EPS foam steel deck panel

In CES-30-12 hybrid panels, when approaching maximum load, followed by cracks in the concrete layer at both working load points (1/3 of the span). The cracks that occurred spread to the top surface of the concrete layer. Whereas, on CES-30-20 and CES-30-30 hybrid panels, as the load increased, the pattern of bending cracks (vertical crack patterns) occurred first in the EPS foam layer, the crack patterns occurred around the load point. In general, cracking first occurs in the bending element of concrete, occurs in the lower fibers. However, in these hybrid panels, the first crack occurred in the core layer (EPS foam) which then radiates to the concrete layer that was above the EPS foam layer, crossing the top surface of the concrete panel layer. On the other hand, on the CES-30-30 panel, a bending crack occurred first in the EPS foam layer. Furthermore, the increased load results in a pattern of bending sliding cracks on the concrete layer along with the widening pattern of cracks in the EPS foam so that the openings are formed starting the collapse of this hybrid panel. At the time of unloading, CES-30-20 and CES-30-30 hybrid panels attempts to return to its original condition, but there was still a significant impact on the panels. Whereas, on the CES-30-12 panel, when the load stopped (unloading), the hybrid panel drastically



returns to its starting position, where there is no deflection. Similarly, the EPSfoam layer which during loading undergoes compaction (approaching the middle of the span), the condition again stretches to the original kinship. There were no cracks in the concrete. Loading was stopped for all panels when the load dial reading was not controlled.

The mechanism of collapse, the crack pattern that occurred in precast reinforced concrete - EPSfoam-steel deck hybrid panels (CES) did not significantly affect hybrid panels with different concrete layers thick, in this study the thickness of panels there are two types, namely 30 mm and 40 mm. However, the density of EPSfoam greatly affects the CES panel collapse mechanism. The results of this study showed that the CES panel collapse mechanism with a density of 20 kg/m<sup>3</sup> and 30 kg/m<sup>3</sup> behaved almost the same. However, collapse mechanism CES panels with a density of 12kg/m<sup>3</sup> are very different.

## 5. Conclusion

The study results of precast reinforced concrete-EPSfoam-steel deck hybrid panels (CES) against bending loads showed that:

1. The use of EPS foam layer with proper density as the core layer on CES panel affects behavior the CES panel subject to bending. The use of EPS foam layer with a density of 20 kg / m<sup>3</sup> was good behavior . Conversely, the use of a high-density EPSfoam layer, 30 kg / m<sup>3</sup> that has high stiffness caused premature failure.
2. The thickness of the concrete layer affects the maximum load of the CES panel significantly. Increase the thickness of the concrete layer from 30mm to 40mm on hybrid panel with a EPSfoam density of 12 kg /m<sup>3</sup>, 20 kg/m<sup>3</sup>, and 30 kg/m<sup>3</sup> achieved a maximum load increase of 33.51%; 46,13%; and 37.35%, respectively.
3. The mechanism of collapse of the CES panel structure element against the bending is different from the concrete panel structure element collapse mechanism. The mechanism of collapse of concrete panel structure elements to the bending load occurs beginning the formation of vertical cracks (bending) in the middle of the span in the lower fiber and spread to the compressed fiber (upper layer). However, the mechanism of collapse of CES panel structure elements occurs beginning with the formation of vertical cracks (bending) in the middle of the span in the EPSfoam layer which is the core layer of the hybrid panel. Furthermore, the collapse mechanism is followed by the process of laminate between the layer of steel plates (the bottom layer of the hybrid plate) with the EPS foam layer (hybrid plate core layer) which is characterized by a change in the shape of the steel layer around the load point; this incident is in line with the propagation of the crack pattern of the EPS foam layer towards the upper fiber (concrete layer).
4. The density of the EPS foam layer on the CES panel affects the collapse mechanism. CES panels with a density of 12 kg /m<sup>3</sup> experience a poor collapse mechanism, deflection occurs quite high and the EPSfoam layer undergoes compression when the maximum deflection is reached; but when unloading, deflection shrinks and EPSfoam conditions expand again. Conversely, hybrid panel with a density of 30 kg /m<sup>3</sup> experience premature failure because it is high stiffness.

## References

- [1] Daniel I. (2009), *Influence of Core Properties on the Failure of Composite Sandwich Beam*, Journal of Mechanics of Materials and Structures, 4, 1271-86
- [2] Davies JM. (2011), *Lightweight Sandwich Construction*, London: Blackwell Science
- [3] Icardi U, Ferrero L.(2009), *Optimisation of Sandwich Panels with Functionally Graded Core and Faces*, Compos Sci Technol. 69, 575-85
- [4] Mamalis A, Spentzas K, Pantelelis N, Manolakos D, Ioannidis M. (2008), *A New Hybrid Concept for Sandwich Structures*, Composite Structures, 83, 335-40

- [5] Mirzapour A, Beheshty MH, Vafayan M. (2005), *The Response of Sandwich Panels with Rigid Polyurethane Foam Cores under Flexural Loading*, Iranian Polymer Journal, 14, 1082-8.
- [6] Moreira R, Rodrigues JD. (2010), *Static and Dynamic Analysis of Soft Core Sandwich Panels with Through-Thickness Deformation*, Composite Structures, 92:201-15.
- [7] Rejab M, Cantwell W. (2013), *The Mechanical Behaviour of Corrugated-Core Sandwich Panels*, Composites Part B: Engineering. 47, 267-77.
- [8] Rejab M, Ushijima K, Cantwell W. (2014), *The Shear Response of Lightweight Corrugated Core Structures*, Journal of Composite Materials, 48, 3785-98.
- [9] Standard A. C393–00 (2000), *Standard Test Method for Flexural Properties of Sandwich Constructions*, ASTM C393.
- [10] Zenkert D. (1995), *An Introduction to Sandwich Construction*, Solihull: EMAS.